



How enterprises are solving evolving network challenges with Passive Optical LAN

Passive Optical LANs provide enormous value to enterprises without forcing them to alter how they do business.

Executive summary

Enterprise businesses that need to upgrade or replace existing telecommunications networks are looking for ways to improve energy efficiency and reduce capital and operating expenses. Technology managers are looking for solutions that furnish high bandwidth while increasing the security and reliability of their networks.

To meet these requirements, enterprises are turning to Gigabit Passive Optical Network (GPON) Optical LANs. Passive Optical LANs provide enormous value to enterprises without forcing them to alter how they do business, while existing services provided by their networks remain the same with no change to core and user devices.

Additionally, enterprises are saving up to 30%–50% of capital costs, 50%–70% of ongoing operational costs, 30%–65% on energy and 90% of the rack space while exceeding their environmental sustainability goals. Plus, businesses deploying Passive Optical LANs experience long-term savings by future-proofing their network infrastructure while realizing all of the benefits of converging their networked services, including voice, video, wireless access, security, surveillance, building environmental controls and building automation with Power over Ethernet (PoE) where needed.

This white paper explains how Passive Optical LANs work and how they can benefit your organization. It also highlights why enterprises are looking to deploy Passive Optical LANs solutions that are environmentally responsible and solve evolving network challenges while significantly cutting CapEx and OpEx, energy consumption and space requirements.

Passive Optical LAN vs. traditional Active Ethernet LAN

A Passive Optical LAN is a Layer-2 transport medium, built with Passive Optical Network (PON) technology, which provides converged video, data, wireless access and voice services at gigabit speeds over a single strand of fiber to the user's location. Comparing the configurations of a traditional Active Ethernet LAN and a Passive Optical LAN architecture helps to illustrate more clearly the similarities between the two technologies [Figure 1].

In a traditional Active Ethernet LAN, a router in the top-most layer (Core Layer) links to the campus or building aggregation switches (Distribution Layer) below. The distribution switches connect down to the Access Layer switches in the communications closets. Copper cables extend from the communications closets to the users and end devices.

In a Passive Optical LAN solution, the router is retained in the top-most layer, and the Optical Line Terminal (OLT) serves the same purpose as the campus aggregation switches. The building aggregation switching is accomplished by the 1x32 (or 2x32 for equipment redundancy and fiber route diversity) optical splitter, which is a passive device, so there are no power requirements and little management while being highly reliable. The Optical Network Terminals (ONTs) provide connectivity to the users and end devices.

It is important to note that both solutions provide data access via 1000BASE-T Ethernet connections to the user. Therefore, no client or PC reconfiguration is required when upgrading from Active Ethernet to a PON infrastructure. Enterprises also have the flexibility to deploy a Passive Optical LAN in a fiber-to-the-desktop topology or a fiber-to-the-communications room. A splitter-equipped fiber distribution hub (FDH) on each floor routes the fiber to the desktop ONTs throughout the building. The fiber-to-the-communications room topology allows for the reuse of existing copper cables between the communications closets and the desks.

A Passive Optical LAN's ONT has all of the required Layer-2 functionality built in. The Passive Optical LAN provides integrated Ethernet bridging, the VLAN capability required for network segmentation, and user authentication and security filtering. The ONT, which functions much like an Ethernet switch, makes it possible for an enterprise to seamlessly replace an Ethernet-switched LAN.

Deliver significant CapEx and OpEx savings

When upgrading your network infrastructure, it is important to look at both the near-term and long-term expenses. Today's enterprises require solutions that not only lower initial capital expenses but also reduce the total cost of ownership (TCO) for the network. Forward-looking managers insist that new systems address more of their telecommunications requirements while minimizing ongoing operational expenses.

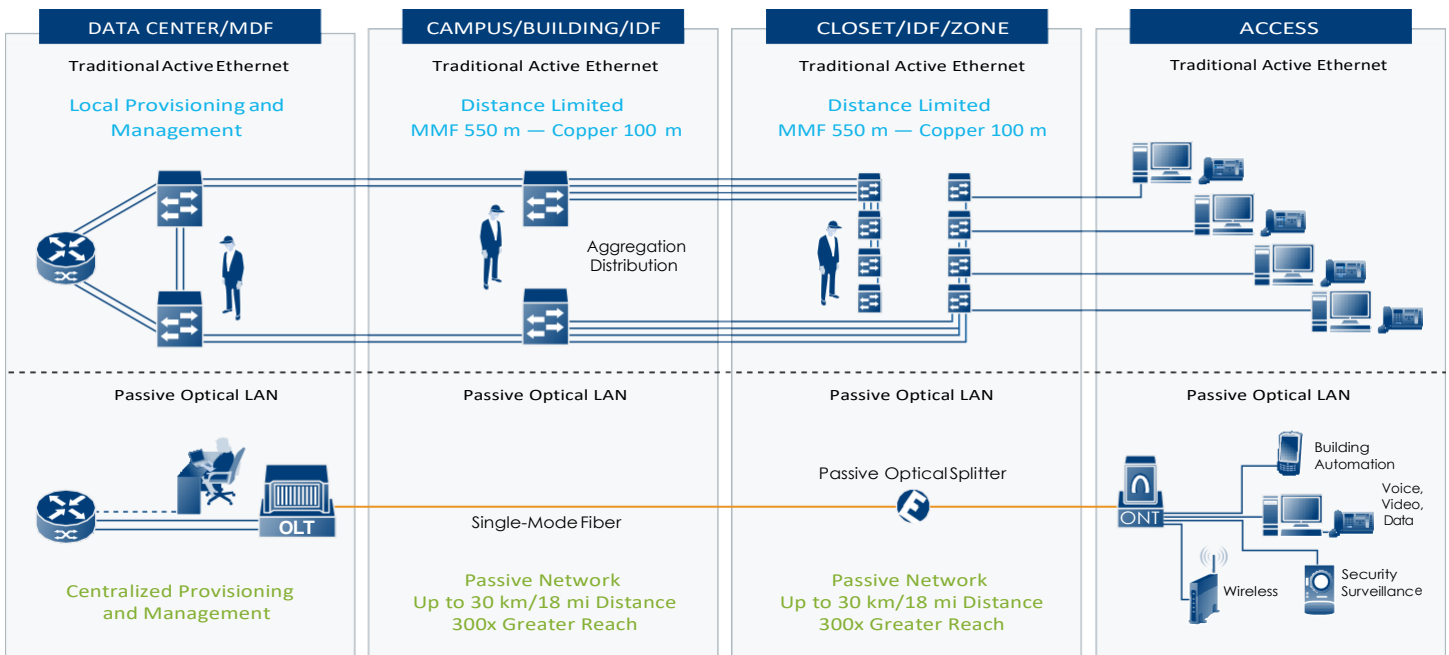

Figure 1: Comparing the configurations of a Passive Optical LAN to a traditional Active Ethernet LAN



Today, the growing market acceptance reflects Passive Optical LAN's ability to support critical enterprise applications with greater efficiency than traditional Active Ethernet.

Passive Optical LAN technology enables the enterprise to significantly reduce the cabling infrastructure costs from the data center to the user by significantly reducing the number of cable runs. The result is a decrease in overall operational costs and network complexity.

Each ONT model supports multiple densities of Gigabit Ethernet, POTS and rF video. This integrated approach provides the ability to connect building automation systems, security cameras and building sensors all on the same infrastructure, thereby removing the requirement and expense of separate transport systems across the campus for each technology. The PON infrastructure also eliminates costly hardware within a network, such as remote switches, as well as their associated provisioning cost, annual maintenance and software licensing fees.

A Passive Optical LAN extends the network life cycle to 10 years or more. This approach enables:

- Gradual, more predictable costs for bandwidth upgrades over the full 10-year period
- Modest ongoing maintenance costs associated with fiber
- Seamless addition of more technology-based capabilities, such as wave division multiplexing 40- and 100-Gbps transport and terabyte switching

Developed for low-cost fiber-based converged network service delivery, GPON standards were finalized by the ITU in 2003 (ITU G984.x). Tellabs first publicly demonstrated standards-based GPON OLTs and ONTs to the North American service provider consortium led by Verizon, AT&T and BellSouth in May 2006.

Today, the growing market acceptance reflects Passive Optical LAN's ability to support critical enterprise applications with greater efficiency than traditional Active Ethernet.

Passive Optical LAN attains up to 95% bandwidth utilization efficiency, whereas traditional Active Ethernet suffers from efficiency rates as low as 69%. Coupled with strong encryption support, Passive Optical LAN delivers the most efficient and secure technology available.

Lower space requirements

Cutting back on floor, rack and closet space is also extremely important to organizations looking to save. Reduction in floor space lowers operating expenses by reducing overhead costs, such as space and HVAC. In addition, the smaller footprint associated with Passive Optical LAN technology enables next-generation performance and services in smaller communication closets not originally designed for advanced communications equipment.

A typical Active Ethernet LAN serving up to 2,016 users requires 90 rack units of space. Active Ethernet LAN switches require one full rack for the switches and two additional racks for terminating the large bundles of copper cables associated with the switches. The total solution would require a total of 18 seven-foot-tall equipment racks.

Comparatively, a Passive Optical LAN serves up to 7,700 users. Due to the OLT's 90% greater density, this solution requires only 1 equipment rack and a total of 9 rack units within the rack.

Additionally, a Passive Optical LAN requires fewer communications closets and, in some cases, eliminates them altogether. As a result, a business can recover physical space and cut expenses. The single-mode fiber in the Passive Optical LAN, however, can reach up to 30 kilometers. This enables an enterprise to:

- Reduce or eliminate repeaters, switches and communications closets
- Deploy an OLT in a single central location

Meet green sustainability objectives

Passive Optical LAN offers power savings of up to 30%–65% over Active Ethernet solutions supporting green initiatives and reducing total cost of ownership. It is a passive architecture; therefore, it requires no power within the Optical Distribution Network (ODN) also known as the outside cable plant, which removes all power requirements from the building aggregation portion of the network.

Not only does less equipment require less power, but it also has a ripple effect on many other areas, including power distribution and switchgear, power conversion and air conditioning cooling. One in five companies now has a dedicated budget allocated for green IT initiatives, and 44 percent say that they are moving toward doing so.

Deploy a future-proof Infrastructure

Installing a single-mode fiber (SMF) infrastructure virtually future-proofs your network. Since SMF has been demonstrated to carry 101 Tbps of full duplex bandwidth, the next-generation network upgrade will not impact the installed fiber distribution network, and you will only need to upgrade the electronics. Utilizing SMF extends the LAN reach out to 30 kilometers without signal regeneration.

Typically, the cable plant is the most expensive part of a technology upgrade. Installing SMF removes the requirement for additional upgrades to your cable plant in the foreseeable future. Additionally, recent advances in fiber connector technology have reduced the cost of installing fiber significantly, and in most cases the installation of fiber is now less labor intensive than installation of a copper cable plant.

Finally, in a direct comparison to CATx copper cable plant, SMF is smaller, lighter and stronger; has a tighter bend radius, higher bandwidth capacity and longer reach; is less susceptible to EMI interference; has faster connector solutions and longer life; and entails less material expense than CATx.

Converge all services

Converging all network services is the foremost feature of the Passive Optical LAN. It will converge all services across a single infrastructure, eliminating the need for multiple platforms while providing highly scalable high-speed data services to all users. Additionally, voice (e.g., analog POTS and VoIP w/PoE), video, video conferencing services, wireless access and monitoring services (e.g., building automation system, security cameras and building sensors) are all supported on the Passive Optical LAN.

Voice — Providing the same services as a legacy switching architecture, VoIP handsets are connected at the Optical Network Terminals (ONTs) via a standard RJ-45 gigabit Ethernet port. The VoIP service is transported to IP PBX or softswitch as standard IP/Ethernet traffic [Figure 2].

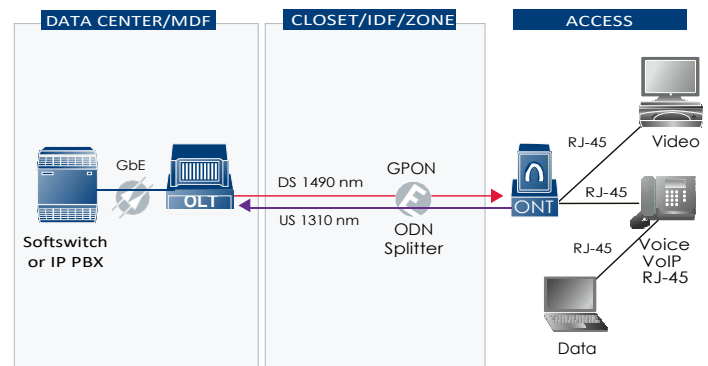

Figure 2: VoIP over Optical LAN architecture

Passive Optical LAN Optical Line Terminals (OLTs) and ONTs can also support analog voice, or what is commonly called Plain Old Telephone Service (POTS). In this scenario, the ONT itself contains a Session Initiation Protocol (SIP) to the analog converter that allows the POTS phone to plug into an RJ-11 port on the ONT [Figure 3]. As the ONT converts the POTS call to SIP, it is transported over the Passive Optical LAN system in a VoIP format, which is handled in one of two ways. The first option is to convert the call back to analog with a voice gateway (vGW) that provides legacy PBX integration or tip/ring lines from the carrier. The second approach ties the POTS phone as a SIP call directly to a VoIP extension on the customer's IP-PBX or softswitch, eliminating the need for VoIP phones to be purchased. Both options provide full integration with the features of the legacy TDM PBX, POTS lines or the VoIP softswitch, and deliver call waiting, message waiting indicator lights, voicemail and all other features to the user via the analog POTS handset.

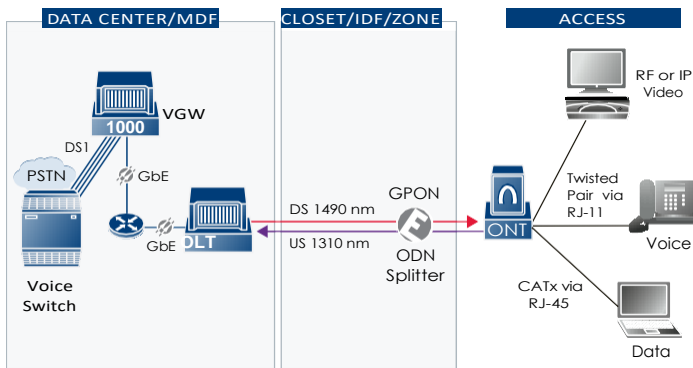

Figure 3: Analog (POTS) over Optical LAN architecture

The ONTs do support IEEE standards for IEEE 802.3af PoE (15.4 watts at an Ethernet port) and IEEE 802.3at PoE+ (25.6 watts at an Ethernet port) to power the voIP handsets [Figure 3]. regardless of the solution being deployed (voIP or POTS services), the Passive Optical LAN system provides the necessary network protocols and quality of service (QoS) required in the modern enterprise environment. This allows for vLAN trunking and creating “daisy chained” PCs fed off of the voIP endpoint with a separate vLAN and QoS settings for each achieved via standards based on IEEE 802.1q and DSCP mappings that guarantee that the voice calls are clear.

Video — Since Passive Optical LAN is a standard transport system, IP video content can be deployed with little effort. As an example, small enterprises are able to encode off-air analog and digital channels, and deliver them in both standard definition and high-definition quality [Figure 4]. These video networks are built to support local cached content for video on demand (voD) and other interactive services. There are even options for local content insertion (e.g., facility news, company news and training). This is accomplished over the Passive Optical LAN equipment, since the video is once again transported in an IP/Ethernet format. As the Passive Optical LAN system leverages Internet Group Management Protocol (IGMP) multicast delivery mechanisms, it is a highly efficient means to deliver video on the network. IGMP multicasting takes place across the OLT and ONTs so as to ensure that only a single copy of the unique IP video stream is efficiently sent across the network, optimizing bandwidth. This same architecture can support enterprise-centric IP video, such as video conferencing (vTC), telepresence conferencing, telepresence robots and video surveillance.

Identical to voice services on the Passive Optical LAN, strict QoS preserves the video content and priority in the network. This is especially critical in video conferencing (vTC) and in telepresence applications. The video is delivered through rate limiting (shaping), queue management (buffering) and

scheduling (policing) mechanisms. Bandwidth rate limiting is set by provisioning the sustained data rate levels and burst or peak rate for proper traffic shaping. Finally, the OLT and ONT queue (buffers) and scheduling (policing) smooths any bursty traffic. All of the above together builds your service level agreements (SLAs) that ensure that the IP video quality is high and the user experience is superior.

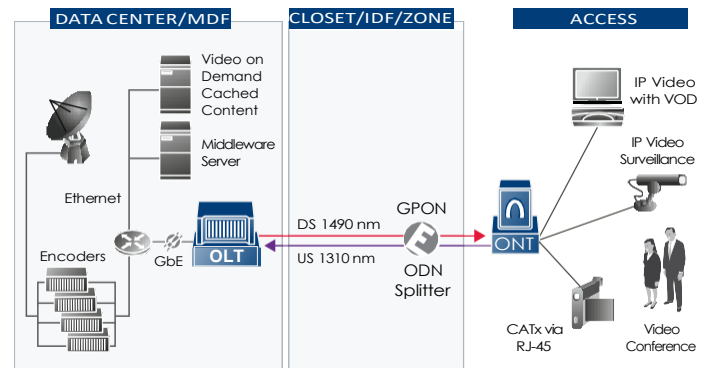

Figure 4: IP video over Optical LAN architecture

If there is rF video, Passive Optical LAN provides video overlay service in compliance with ITU-T G.984. The rF video is carried on the system using a third wavelength (1550 nm) [Figure 5]. The video signal format delivered to the customer is defined by SCTE standards. From the ONT, a standard 750-ohm coaxial interface supports 54–900 MHz CATv channel content. Since this is accomplished over a separate wavelength, the rF video network equipment is not aware of the Passive Optical LAN presence. With the centralized management of the Passive Optical LAN, the coaxial output can be tuned to match the signal levels required for the customers remotely and allow for remote balancing of the network.

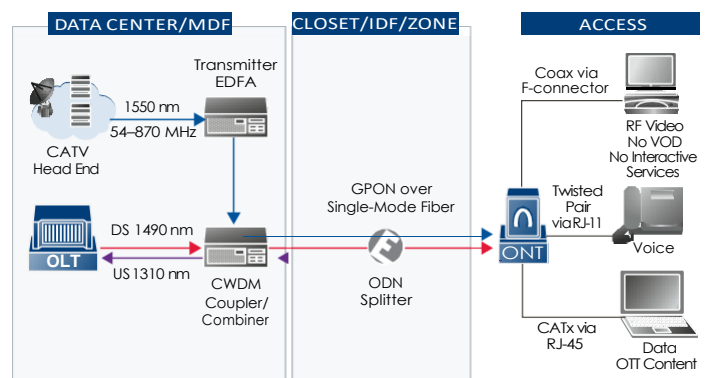

Figure 5: rF video over Optical LAN architecture

Wireless — Passive Optical LAN can also be used for wireless backhaul transport of the access points traffic. It can do so in two architectures. First, there is the stand-alone static Wi-Fi architecture with no robust controller functionality. In this scenario, Passive Optical LAN can provide the benefits of lower equipment cost, reduced energy and collapsed cabling infrastructure. There are also wireless access point (WAP) features and functionality integration that can be accomplished with Passive Optical LAN via the centralized management platform. Passive Optical LAN provides a greater system reach for improved performance and coverage for Wi-Fi service. As Passive Optical LAN interoperates with established Wi-Fi vendors, it allows for Wi-Fi controller functionality to be provided by best-of-breed Wi-Fi manufacturers without limiting the customer's options [Figure 6]. The controller functionality adds dynamic provisioning, interference correction, load balancing and coverage optimization as is required in a true enterprise deployment. Today, there is Passive Optical LAN deployment with industry leaders like Cisco, Aruba, Ruckus and Meru.

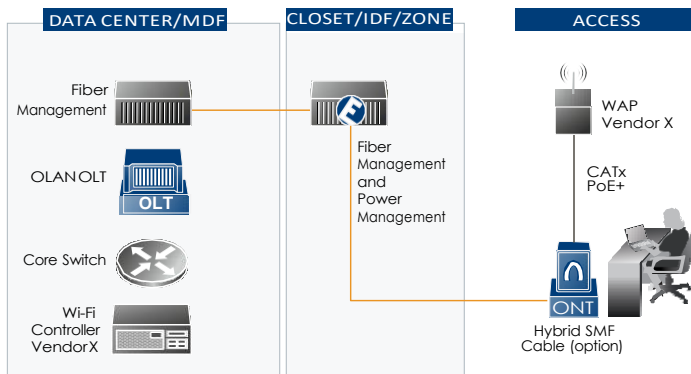

Figure 6: Wi-Fi over Optical LAN architecture

There are also synergies between distributed antenna systems (DAS) and Passive Optical LAN. To be clear, the DAS traffic does NOT traverse the Passive Optical LAN equipment, but it can leverage the same fiber infrastructure that Passive Optical LAN utilizes [Figure 7]. Alone, DAS has a challenging return-on-investment analysis — it is relatively expensive; it only does one thing; and the end customers think they should not have to pay for it. Passive Optical LAN has an excellent ROI that can justify the deployment of DAS over existing spare fibers. In the near term, DAS and Passive Optical LAN can gain additional synergies with combined powering, power backup and fiber management between them. In the future as both DAS and Passive Optical LAN technologies advance, it can be expected that the Passive Optical LAN ONT can integrate both DAS antenna and Wi-Fi WAP hardware.

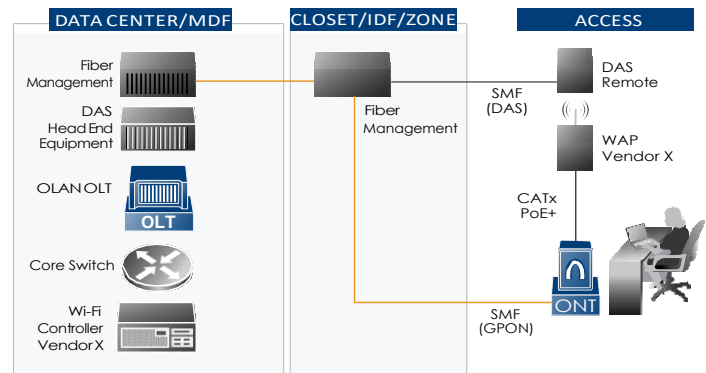

Figure 7: DAS over fiber with synergies with Optical LAN architecture

Once again, it should be noted that the ONTs do support IEEE standards for IEEE 802.3af PoE and IEEE 802.3at PoE+ to power the Wi-Fi WAPs. These ONTs provide powered device (PD) management, monitoring and configuration using LLDP. Thus, the ONT detects the actual power requirements of a PD and then adjusts the power allocation for that PoE port. There are also mechanisms for providing reports on power consumption so that IT managers can adjust deployment configurations to low-power modes for devices like WAPs and IP phones alike.

Smart/Intelligent Buildings — A Building Management System (BMS) and Building Automation System (BAS) are extremely important for any new high-performance buildings and a key to reducing operating costs. Building monitoring devices and system reporting and analysis tools require IP/Ethernet connectivity. In recent years, the Passive Optical LAN has taken on the responsibility to integrate these functions. Since the majority of BMS/BAS monitoring devices today are IP/Ethernet based, the connectivity into the existing (or new) Passive Optical LAN is seamless [Figure 7]. The Passive Optical LAN can ensure adequate bandwidth, security, authentication and quality of service specific to each monitoring and management device.

Smooth upgrade path to next-generation services

Passive Optical LAN supports legacy voice, including Session Initiation Protocol (SIP); video, including IPTv and rF over Glass (rFoG); high-speed data; and business services. The ITU created the GPON standard with the ability to support multiple services, and Passive Optical LAN takes advantage of this capability by providing a smooth upgrade path from existing to next-generation services. The Passive Optical LAN easily scales as the campus network expands and evolves, providing a simple and cost-effective migration path.

Single Mode Fiber — Compared to copper cabling, single mode fiber is smaller, lighter and stronger with a better bend radius and longer reach. It is less susceptible to interference, has faster connector solutions and a longer life, and is more secure and less expensive. On top of all of those great benefits, fiber cabling also has higher bandwidth capacity, with upper thresholds that are only limited by today’s technology.

That means that the current generation OLAN OLT, optical distribution splitter and SMF cabling will not need to be replaced when the time comes to upgrade the network to next-generation Passive Optical Networking technology in support of 10 gigabit and 40 gigabit speeds [Table 1].

Cable	Cost	Diameter	Weight	Bend Radius	Pull Tension	Future Capacity
Six 300ft Copper CAT6a	\$594 1,800 feet	1 inch bundle	70 pounds	Curve over 1 inch	25 pounds	Measured in Gigabits
Two 300ft Fiber (SMF)	\$66 600 feet	Less than 1/8 inch	Little over 2 pounds	Curve Less than 1/4 inch	48 pounds	Measured in Terabits

Table 1: A comparison of CAT6A copper cabling to Single Mode Fiber (SMF) cabling



Improve security and reliability

Passive Optical LAN is highly secure and produces none of the EMI radiation that is typically associated with traditional copper-wired facilities. Utilizing fiber optic cable for the transport mechanism effectively removes all TEMPEST concerns. In addition, Passive Optical LAN provides powerful security measures at the physical layer, data layer and at the user port to greatly reduce the potential for Denial of Service (DoS), redirects or other malicious attacks.

Passive Optical LAN provides significant benefits without forcing enterprises to alter what they are already doing or changing out the core and user devices.

Passive Optical LAN provides access control lists (ACLs), broadcast datagram rate limiting at each user device and strong authentication. Authentication based on 802.1x allows multiple devices per user port along with advanced intrusion detection — effectively locking down the physical port upon detection of an untrusted device. ACLs provide flexibility to statically and/or dynamically permit/deny datagrams based on Layer 2 (Ethernet) rules, Layer 3 (IP) rules, Layer 4 (TCP/UDP) rules and network access control (NAC).

Time-saving Passive Optical LAN training

Getting a Passive Optical LAN up and running is easy. The amount of training required to test and turn-up the Passive Optical LAN is far less than with an Active Ethernet network. Simplified training is possible due to the central management of the EMS system combined with the central intelligence provided by the OLT, which simplifies and reduces the amount of training required to support a Passive Optical LAN network. The Passive Optical LAN Test and Turn-up class includes the Passive Optical LAN and EMS system and is typically only 3½ days long, compared to the several weeks of training that are typically required for a traditional Active Ethernet network.

Summary

Enterprises looking to upgrade or replace their network infrastructure are realizing the value of Passive Optical LAN. Passive Optical LAN provides significant benefits without forcing enterprises to alter what they are already doing, or changing out the core and user devices. Businesses are saving up to 30%–50% of capital costs, 50%–70% of ongoing operational costs, 30%–65% on energy and 90% of the space while exceeding green goals and gaining assistance in acquiring LEED facility certification.

Deploying a Passive Optical LAN helps an enterprise future-proof their network infrastructure while realizing all of the benefits of converged network services. The Passive Optical LAN provides solutions that furnish high bandwidth while increasing the security and reliability of existing networks.

Take the next step. Contact Mechdyne today.



11 East Church Street
Marshalltown, IA 50158

+1 641 754 4649
www.Mechdyne.com



© 2017, Tellabs Access, LLC. All rights reserved.

4240 Int'l Parkway Suite 105
Carrollton, TX 75007 USA

+1 800 690 2324
www.telllabs.com